

Structural Fasteners for Connecting Timber-To-Timber

Strong-Drive® SDWC TRUSS Screw

The Strong-Drive® SDWC TRUSS screw provides a truss and rafter-to-top plate connection as well as a method to fasten studs to top or bottom plates. The fully-threaded shank engages the entire length of the fastener providing a secure connection.

Material: Carbon steel.

Finish: SDWC15450—E-Coat™; SDWC15600—Clear Zinc Coating (with Orange Topcoat). See Corrosion Information.

Related Links For more information and drawings [click here to visit webpage](#)

Technical Data

Model No.	Fastener Length (mm)	Thread Length (mm)	Side Member (SG8)	Main Member (SG8)	Characteristic Lateral Load, R_k (kN)		Characteristic Load, R_k (kN)
					F_1	F_2	
SDWC15450	114	108	Single Plate (45mm)	Single Stud (45mm)	—	3.5	6.1
			Double Plate (80–90mm)	Single Joist/Rafter (45mm)	2.8	4.3	11.8
SDWC15600	152	136	Single Plate (45mm)	Single Stud (45mm)	—	2.5	6.1
			Double Plate (80–90mm)	Single Stud (45mm)	—	3.5	8.9

1. Main Member is the part where the fastener tip is embedded. Side Member is the part adjacent to the fastener head.
2. F_1 is loading parallel to the wall (in the wall plane). Minimum penetration into the main member shall be 25 mm.
3. F_2 is loading perpendicular to the wall (out of the wall plane). Minimum penetration into the main member shall be 25 mm.
4. Uplift is calculated by taking the lowest of the withdrawal and pull-through load.
5. Shear values may be doubled if two fasteners are used. Uplift values must be multiplied by 0.75 if two fasteners are used.

Model No.	Fastener Length (mm)	Thread Length (mm)	Main Member (SG8)	Characteristic Withdrawal Load, $R_{k,w}$ (N/mm)	Characteristic Pull-through Load, $R_{k,w}$ (N/mm)
SDWC15450	114	108	End Grain Single Stud (45mm)	96	117
SDWC15600	152	136	Edge Single Joist/Rafter (45mm)	166	—
			Face Single Plate (45mm)	139	133
			Face Double Plate (80–90mm)	147	164

1. Withdrawal is the capacity of the fastener tip pulling out of the main member.
2. Pull-through is the capacity of the head pulling through the side member.

Typical Roof-to-Wall Connection

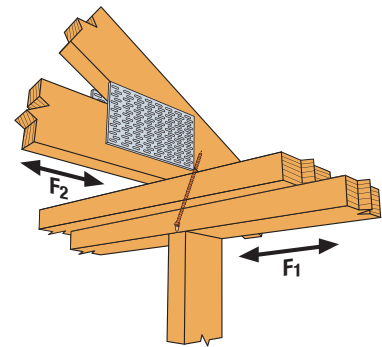

Typical single SDWC installation

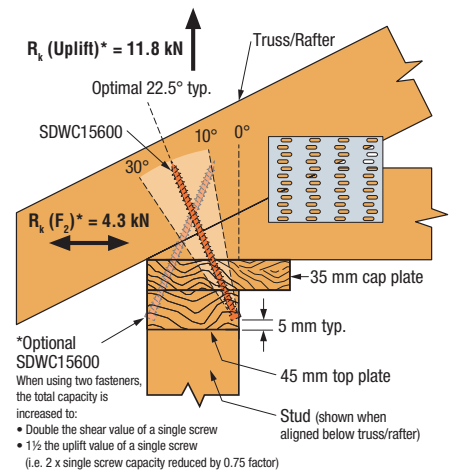

Uplift and Shear Capacity Truss/Rafter to Plate Condition (Optional second screw lighter shade)

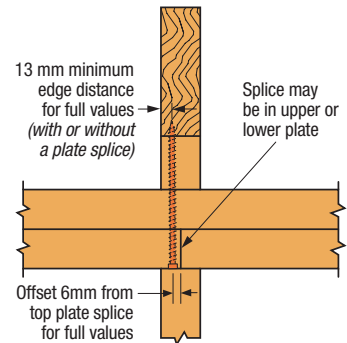

Min. edge distance for top plate splice

Stud-to-Plate Connections

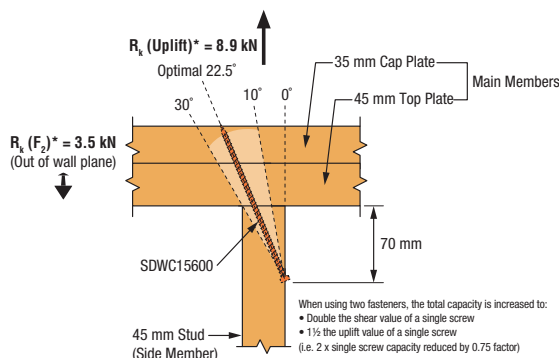

Stud-to-top plate condition
(This application requires SDWC15600)

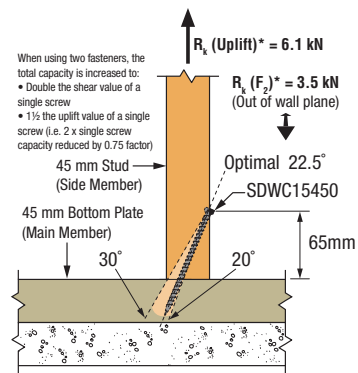

Stud-to-bottom plate condition over concrete/masonry foundation
(This application requires SDWC15450)

Structural Fasteners for Connecting Timber-To-Timber

Strong-Drive® SDWC TRUSS Screw Features

Orange colour for easy inspection of 152 mm screws

6-Lobe Drive reduces cam out, enabling easier driving

Fully-threaded shank engages the entire length of the fastener, providing a secure connection between the roof and wall framing members

Cap-style head countersinks fully into the double top plate to avoid interference with drywall or finish trades

E-Coat™
Black electrocoating for 114 mm screws

Type-17 point for faster starts and easier driving

Installation guide (included) to help ensure proper installation angle

- Wide tolerance on installation angle makes it easy to install the SDWC correctly
- Matched-tolerance driver bit (included) engages fastener head securely to allow one-handed driving (replacement bit part no. BIT30T-R1)
- Can be installed from inside the structure, eliminating exterior work on the upper stories and enhancing job safety
- Fastening can be performed before or after exterior sheathing is applied for added flexibility

Product and Packaging Information

Fastener Model	Length (mm)	Finish	Bit Included	Guide Included	Fasteners Per Pack	Packs Per Carton	Model No.
SDWC15600	152	Clear Zinc Coating (with Orange Topcoat)	BIT30T	SDWC-GUIDE	50	6	SDWC15600-KT
SDWC15450	114	E-Coat Black	BIT30T	SDWC-GUIDE275	50	6	SDWC15450-KT

